

FA'05

ECE 110
Professors Brunet and Trick

October 17, 2005

HOUR EXAMINATION #2

LAST Name (use capital letters): _____

First Name (use capital letters): _____

Signature: _____

Circle your section: AL1(3pm)-Trick

BL1(1pm)-Brunet

DO NOT TURN THIS PAGE UNTIL YOU ARE TOLD

Problem	Value	Score
1	20	
2	20	
3	10	
4	10	
5	20	
6	20	
Total	100	

A. Write or print clearly. Answer each problem on the exam itself. If you need extra paper, there is an extra sheet at the end of this exam. Clearly identify the problem number on any additional pages. The Boolean Algebra identities are also given at the end of the exam.

B. In order to receive partial or full credit, **you must show all your work**, e.g., your solution process, the equation(s) that you use, the values of the variables used in the equation(s), etc. You must also include the unit of measurement in each answer.

Students caught cheating on this exam will earn a grade of F for the entire course. Other penalties may include suspension and/or dismissal from the university.

Problem 1 (20 points)

At least one of the four circuits below is the following waveform rectifier: the output waveform V_{out} is the negative portion of the input waveform V_{in} (i.e., $V_{out} = V_{in}$ when $V_{in} < 0$, $V_{out} = 0$ when $V_{in} > 0$). State which circuit it is and explain why, using the ideal diode model ($V_{on} = 0$):

(*) { You must draw the linear circuit for each assumption,
completely analyze the circuit, and validate each assumption made.

NOTE: If you start with the wrong circuit, start analyzing it, and show it does not work while following directions (*), you will receive some partial credit.

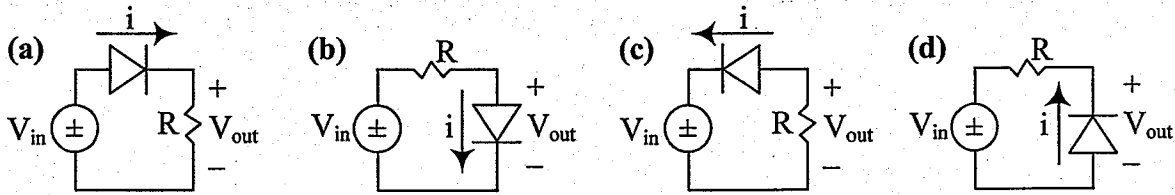

• The circuit is (a) (b) (c) (d)

• Explanation (follow (*))!

When the diode is on:

draw:

analyze:

validate:

Summary: when V_{in} , V_{out}

When the diode is off:

draw:

analyze:

validate:

Summary: when V_{in} , V_{out}

Problem 2 (20 points)

For the given BJT inverter circuit

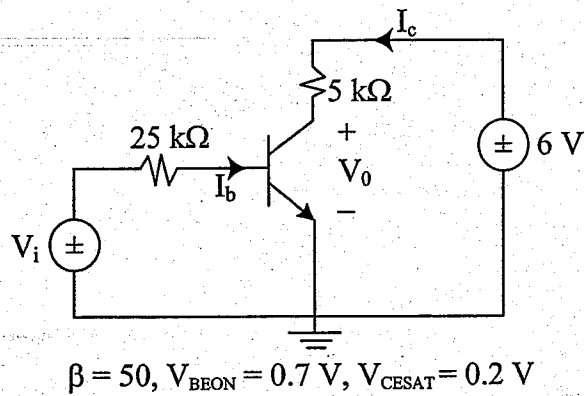

(a) assume that the transistor is operating in the active region and write the KVL equations for the input and output loops. Find the function $V_0 = f(V_i)$ in terms of the circuit and transistor parameters.

(b) If $V_i = 1 + 0.4 \sin \omega t$, use the result in Part (a) to find $V_0(t)$.

Problem 2 (continued)

(c) If your result in Part (b) is not a good approximation to the actual output voltage in the given BJT inverter circuit, sketch a better approximation of the output waveform over one period below.

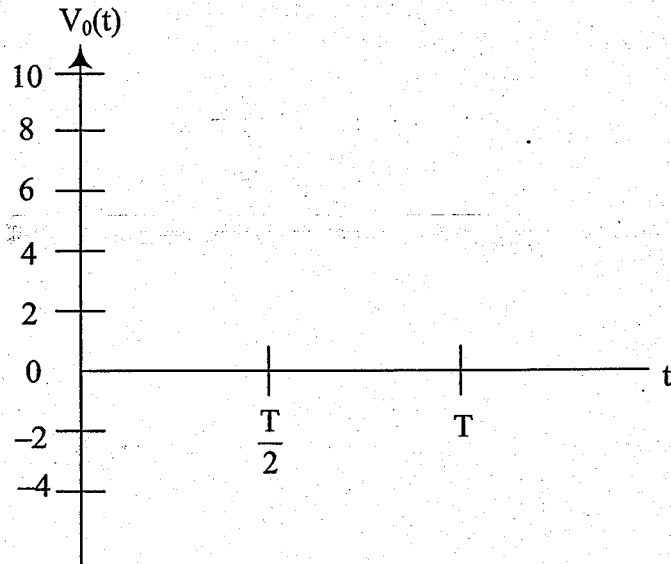

Problem 3 (10 points)

Complete the truth table for the given CMOS circuit. A high voltage represents a logic "1," and a low voltage a logic "0."

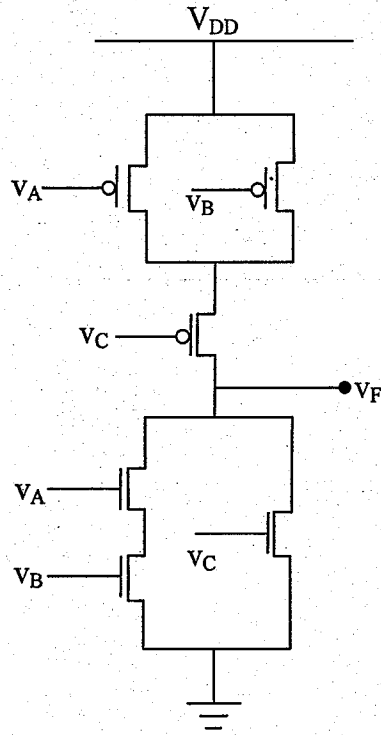

A	B	C	F
0	0	0	
0	0	1	
0	1	0	
0	1	1	
1	0	0	
1	0	1	
1	1	0	
1	1	1	

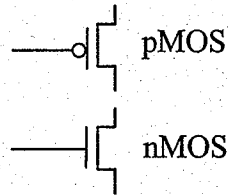

Problem 4 (10 points)

Implement the exclusive NOR gate below using only NAND gates.

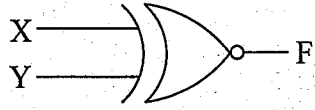

X	Y	F
0	0	1
0	1	0
1	0	0
1	1	1

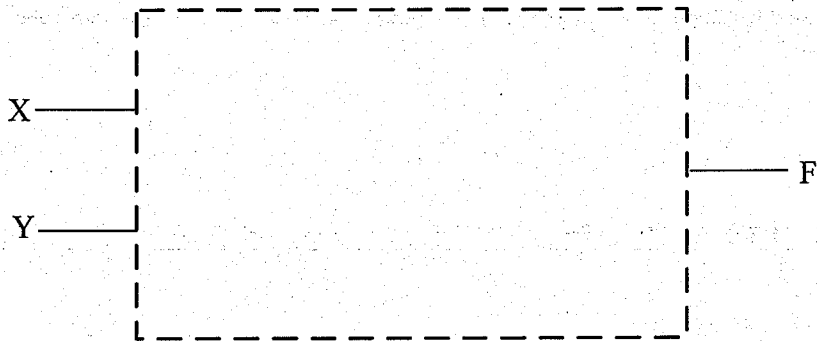

Problem 5 (20 points)

Consider the Boolean function F given by the truth table below:

X	Y	Z	F	X	Y	Z	F
0	0	0	0	1	0	0	1
0	0	1	0	1	0	1	0
0	1	0	1	1	1	0	1
0	1	1	0	1	1	1	0

(a) (4 pts.) Write the canonical sum of product expression for F .

$F(X, Y, Z) =$

(b) (16 pts.) You must choose an optimized circuit for F . For each circuit below explain why you would choose it or not. Write neatly!

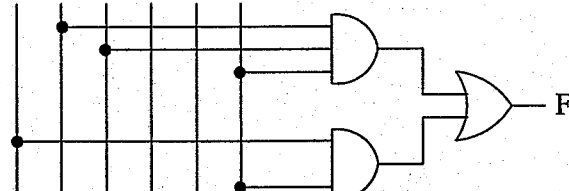
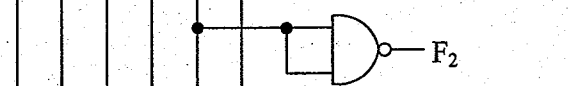
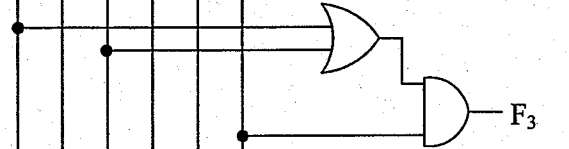
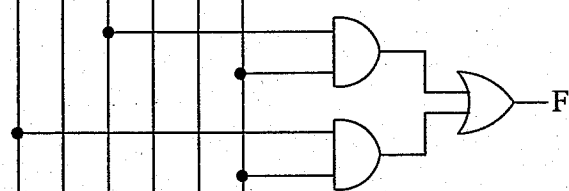
X \bar{X} Y \bar{Y} Z \bar{Z}	explanations
	<input type="checkbox"/> YES <input type="checkbox"/> NO
	<input type="checkbox"/> YES <input type="checkbox"/> NO
	<input type="checkbox"/> YES <input type="checkbox"/> NO
	<input type="checkbox"/> YES <input type="checkbox"/> NO

Problem 6 (20 points)

For each question below, check the one most correct answer.

1) The “sum” output of a full adder can be implemented using NAND gates only.

- always sometimes never

2) The “carry” output of a half adder can be implemented using NAND gates only.

- always sometimes never

3) A half adder can be implemented using a full adder.

- always sometimes never

4) A full adder can be implemented using half adders and few gates.

- always sometimes never

5) With 8 bits it is possible to represent:

- 8 numbers 256 numbers 3 numbers 24 numbers

6) The largest decimal number that can be represented using 3 hexadecimal digits is:

- $3 \times 16 - 1$ $3^{16} - 1$ $16^3 - 1$ $2^{3 \times 16} - 1$

7) To display the decimal value of one hexadecimal digit we need:

- (one two four sixteen) 7-segment displays

8) A 7-segment display can be used to display (check all that apply):

- some decimal digits some letters
 all decimal digits all letters