

**Problem 1** (20 points)

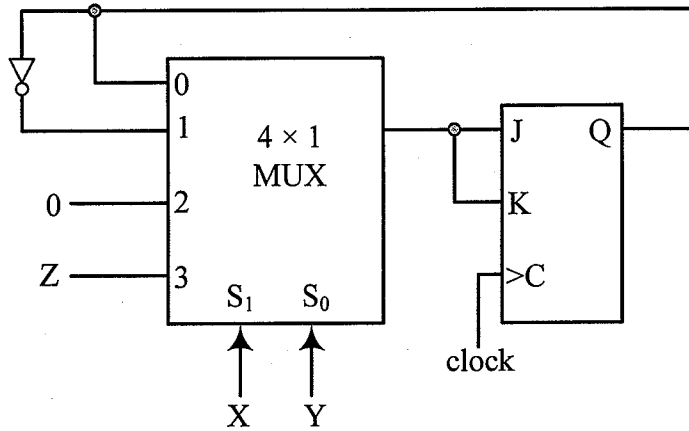

Fill in the following table for consecutive clock pulses.

t	0	1	2	3	4
X	0	1	1	1	0
Y	1	1	1	0	0
Z	0	0	1	1	1
J					
K					
Q	0				

**Problem 2 (20 points)**

Check the most appropriate answer for all questions below.

a)

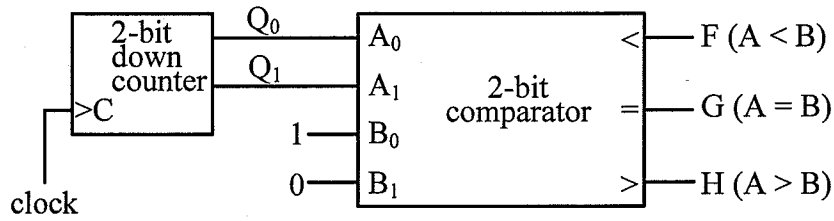

The duty cycle of F is:  0%     25%     33%     none of the previous

The period of G is:  T     2T     3T     none of the previous  
T is the clock period.

b)

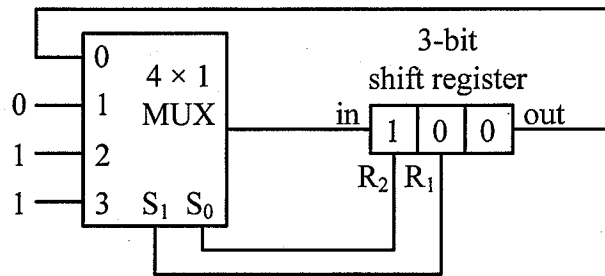

(At  $t = 0$ ; clock is omitted.)

After 2 clock pulses (at  $t = 2$ )  
the register contains:

101     011

000     111

none of the previous

**Problem 3** (20 points)

A wheel has 3 evenly spaced spokes. Each spoke is of a different color (see figure). The wheel is rotating at a rate of  $f = 12$  revolutions per second. Show work of all parts.

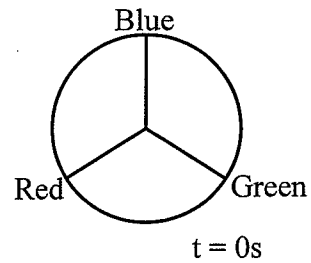

- a) If the wheel is filmed at a sampling frequency  $f_s = 36$  frames per second, is there aliasing?  YES  NO

Draw the first frame seen after  $t = 0s$ ; indicate time, too.

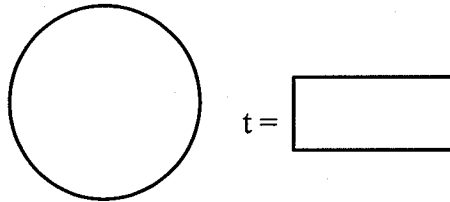

- b) For what sampling frequency would the wheel seem immobile? (Give the largest number possible.)

$f_s =$

- c) For what ranges of sampling frequencies would the wheel seem to be going backward? (Give largest numbers possible.)

$< f_s <$

**Problem 4 (20 points)**

- a) (10 pts.) Information is encoded in the 7-bit ASCII code. In transmission tests it is discovered that on the average a single bit error occurs in every few hundred characters received. A decision is made to add the capability to detect and correct single bit errors. Two schemes are proposed: [a] send the message in triplicate, or [b] add an even parity bit to the code for each character and, for every block of 10 characters to be transmitted, add a redundancy check code word in order to correct any single error that is detected. Compute the compression ratio and savings if Scheme [b] is used instead of Scheme [a].

$R_{\text{compression}} =$

Savings =

- b) (10 pts.) The relative frequency for a message consisting of the following six symbols is  $A = 1/3$ ,  $B = 5/24$ ,  $C = 1/6$ ,  $D = 1/6$ ,  $E = 1/12$ ,  $F = 1/24$ . The Huffman code for these symbols is A(11), B(01), C(00), D(101), E(1001), F(1000). Compute the average code length, and the savings achieved over the minimum fixed length code.

$L_{\text{avg}} =$

Savings =

