

Problem 5 (15 points)

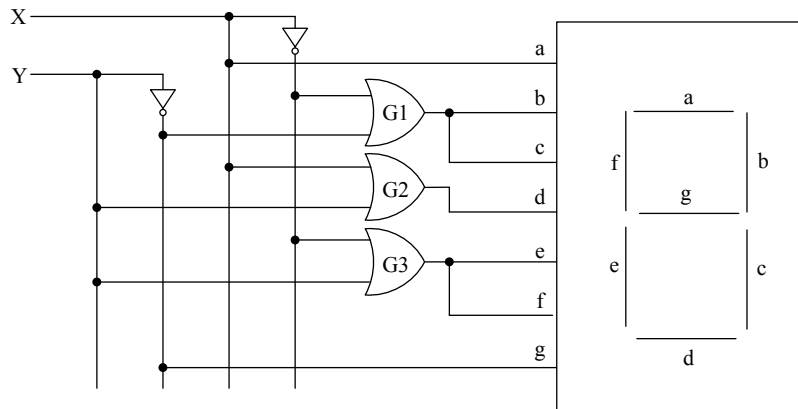

Complete the table below. Show your work.

| X | Y | a | b | c | d | e | f | g | display |
|---|---|---|---|---|---|---|---|---|---------|
| 0 | 0 | | | | | | | | |
| 0 | 1 | | | | | | | | |
| | | | | | | | | | |
| 1 | 0 | | | | | | | | |
| 1 | 1 | | | | | | | | |

Problem 5 (20 points)

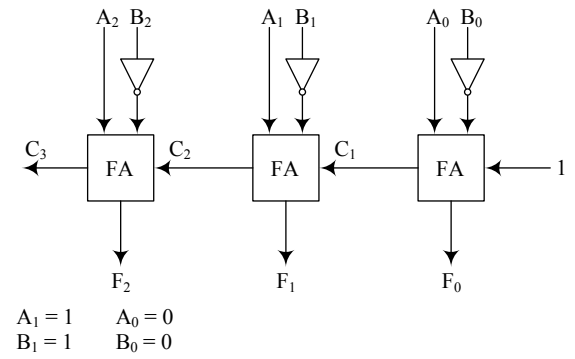

(a) (2 pts.) What is the decimal value corresponding to $A_2A_1A_0$ (binary 110)?

Answer = ₁₀

(b) (2 pts.) What is the decimal value corresponding to $B_2B_1B_0$ (binary 010)?

Answer = ₁₀

(c) (6 pts.) Find values for C_1 , C_2 , and C_3 in the circuit above.

$C_1 =$ ₂

$C_2 =$ ₂

$C_3 =$ ₂

(d) (6 pts.) Find values for F_0 , F_1 , and F_2 in the circuit above.

$F_0 =$ ₂

$F_1 =$ ₂

$F_2 =$ ₂

(e) (2 pts.) What is the decimal value corresponding to the three bits $F_2F_1F_0$?

Answer = ₁₀

(f) (2 pts.) What 3-bit arithmetic function does this circuit implement?

Problem 6 (20 points)

a) [5 pts.] Convert all numbers as requested.

$$(A B)_{16} = (\quad)_{10}$$

$$(2 3)_{16} = (\quad)_{10}$$

$$(2 3)_5 = (\quad)_{10}$$

b) [15 pts.] For the given circuit, fill out the table below.

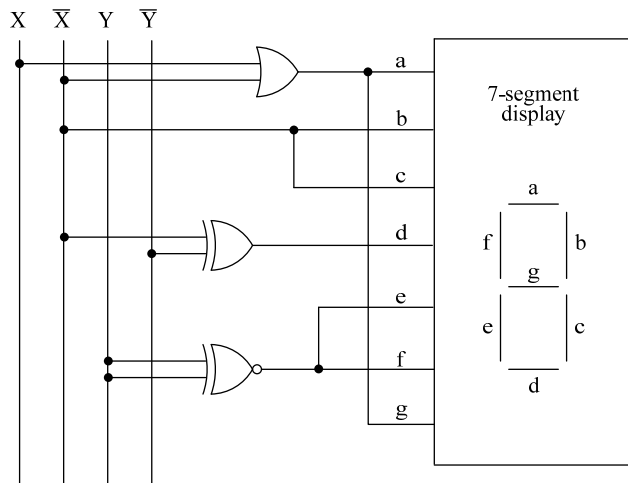

| X | Y | a | b | c | d | e | f | g | display |
|---|---|---|---|---|---|---|---|---|---------|
| 0 | 0 | | | | | | | | |
| 0 | 1 | | | | | | | | |
| 1 | 0 | | | | | | | | |
| 1 | 1 | | | | | | | | |

Problem 5 (20 points) The Boolean function $h(x, y, z)$ is defined by the truth table below.

| x | y | z | h |
|---|---|---|---|
| 0 | 0 | 0 | 0 |
| 0 | 0 | 1 | 1 |
| 0 | 1 | 0 | 1 |
| 0 | 1 | 1 | 0 |
| 1 | 0 | 0 | 1 |
| 1 | 0 | 1 | 1 |
| 1 | 1 | 0 | 1 |
| 1 | 1 | 1 | 0 |

(a) [10 pts.] Find a sum-of-products (SOP) expression for h that has only three product terms.

$h =$

(b) [6 pts.] Find a canonical SOP expression for the **complement** of h .

$h' =$

(c) [4 pts.] Draw a two-level AND-to-**NOR** circuit that implements the **original** function h . Assume that the variables x, y, z and their complements x', y', z' are available as inputs. [Hint: use the result of part (b).]

