

Chapter 3

Lab 3 - Broadband RF Amplifier

3.1 Introduction

The goal of this lab is to design, simulate, construct, and characterize a broadband small-signal amplifier that will operate over a frequency range of (at least) 10-100 MHz. You will become familiar with:

- S-parameter measurements using the network analyzer and S-parameter test set
- accurate component characterization using the network analyzer
- use of ADS computer aided design software to develop models for components, to simulate the performance of an amplifier, and to fine-tune the design of the amplifier
- measurement of 1 dB compression point
- measurement of two-tone third-order intercept level
- measurement of noise figure

The following design specifications are to be met:

1. ~ 18 dB gain over 1 decade (10-100 MHz). The gain characteristic should be as flat as possible.
2. $\sim 50 \Omega$ input and output impedances when used in a 50Ω system (i.e. at least 15 dB input and output return loss from 10-100 MHz). Return loss is defined as $10 \log |S_{ii}|^2$ where $i = 1$ for input return loss and $i = 2$ for output return loss.
3. the amplifier should be unconditionally stable at all frequencies

Compared to Labs 1 and 2, you will find that this laboratory exercise requires significantly more initiative on your part if you are to achieve satisfactory results. You will not be provided with detailed step-by-step instructions for each and every aspect of the lab. Instead, we will provide enough background information to get you started, and then you are on your own. Your TA's will, of course, make every effort to answer your questions and to provide assistance when problems arise.

3.2 Theoretical analysis of the broadband amplifier

3.2.1 Overview

There are basically two approaches that can be taken when designing an amplifier that must operate with reasonable gain and good input/output impedance match over a wide bandwidth. One approach is to use impedance transformation networks at the input and output of the active network and to design the networks so that the frequency-dependent variations in the active network's gain and impedance are compensated for (to a certain extent) by the impedance transformation networks. It is difficult to simultaneously obtain a "flat" gain characteristic together with good impedance match over a wide bandwidth using this approach. The other approach, which is employed in this lab, is to employ negative feedback around the active device in an attempt to modify its characteristics (input/output impedance and power gain) such that they become more-or-less independent of frequency (over some bandwidth) *and* equal to some desired target values. Another advantage of employing negative feedback is that the properties of the circuit can be made to depend primarily on the values of the feedback circuit elements and to be more-or-less independent of the particular characteristics of the active device (such as transistor β , bias current, etc.).

The circuit that will be used for the broadband amplifier is shown in Figure 3.1. Negative feedback is provided by series feedback resistor R_e and shunt feedback resistor R_f . Both types of feedback are necessary in order for us to be able to control both the gain and the input/output impedances of the amplifier. As we shall see, the shunt feedback resistor can be selected to provide a simultaneous match to $50\ \Omega$ at both ports, and the series feedback resistor can be selected to set the gain of the amplifier. The transformer shown in the circuit functions as a broadband 4 : 1 impedance transformer which transforms a $50\ \Omega$ load impedance to approximately $200\ \Omega$ at the collector of the transistor and also provides a convenient pickoff point for the feedback provided by R_f . This transformer must be constructed so that its properties are nearly independent of frequency. This circuit should operate over a fairly wide bandwidth. In practice, bandwidth will be limited by parasitics and the properties of the broadband transformer.

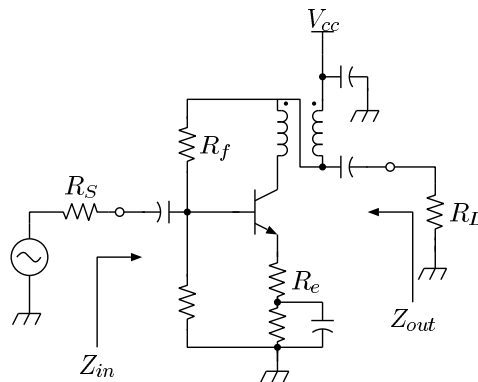

Figure 3.1: Unlabeled capacitors are coupling and bypass elements. The transformer is implemented using bifilar windings on an Amidon FT37-61 ferrite core. Unlabeled resistors are DC bias elements and have no essential function at RF frequencies (although they cannot be neglected when modeling the amplifier).

In the circuit shown in Figure 3.1, it is assumed that the value of the feedback resistor, R_f , is large enough so that it can also serve as one of the two resistors in the voltage divider that develops the base voltage. If RF circuit design considerations dictate that R_f should be chosen to be smaller than is reasonable for the bias network, an additional resistance can be used in series with R_f and this resistor would then be bypassed with a capacitor.