

University of Illinois at Urbana-Champaign

## ECE 461: Communications II

Spring 2005  
Final Exam

Saturday, May 7, 8-11 a.m., Room 169 Everitt Laboratory

Name: \_\_\_\_\_

- You have three hours for this exam. The exam is closed book and closed note, except you may consult both sides of three  $8.5'' \times 11''$  sheets of notes in ten point font size or larger, or equivalent handwriting size.
- Calculators, laptop computers, Palm Pilots, two-way e-mail pagers, etc. may not be used.
- Write your answers in the spaces provided.
- **Please show all of your work. Answers without appropriate justification will receive very little credit.** If you need extra space, use the back of the previous page.
- There are four problems with a total of 25 parts. Each of the parts is worth four points, for a total of 100 points.

Score:

1. \_\_\_\_\_ (28 pts.)

2. \_\_\_\_\_ (20 pts.)

3. \_\_\_\_\_ (28 pts.)

4. \_\_\_\_\_ (24 pts.)

Total: \_\_\_\_\_(100 pts.)

1. (28 points) *Concisely* answer each of the following seven questions.

(a) Name one advantage of using a raised cosine function as a system waveform (in comparison to a sinc waveform) and one disadvantage.

(b) Name one advantage of using the duobinary function as a system waveform (in comparison to a sinc waveform) and one disadvantage.

(c) Name one advantage of noncoherent detection over coherent detection, and one disadvantage.

(d) Explain one advantage of using an interleaver (specify the context) and one disadvantage.

(e) What is an advantage of using fractional spacing (such as  $\tau = \frac{T}{2}$ ) in an equalizer? What is a disadvantage?

(f) What sort of modulation would you suggest for low rate communication to a satellite in deep space, and why?

(g) What sort of modulation would you suggest for high speed data communication over a one kilometer long pair of copper twisted wires (such as a short central office to home telephone line), and why?

2. (20 points) Suppose that the signal  $s_m(t) = u_m(t) \cos(2\pi f_c t + \phi)$  is used to transmit a bit  $m \in \{0, 1\}$ , where the waveforms  $u_1$  and  $u_0$  are pictured. The signal is subjected to AWGN with two-sided power spectral density  $\frac{N_0}{2}$ . Assume that  $f_c T \gg 1$ .

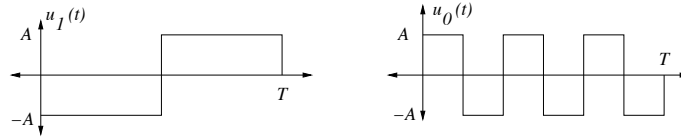

(a) Express  $\frac{\mathcal{E}_b}{N_0}$  in terms of  $A$ ,  $T$ , and  $N_0$ .

(b) Carefully sketch the minmax optimal receiver in matched filter form. Specify the impulse response and threshold value. Include the carrier tracking loop, but you needn't indicate the components of the carrier tracking loop.

(c) Give the error probability for the receiver of part (b). What is the effective loss in energy efficiency, expressed in dB, for not using an antipodal pair of signals?

(Problem 2 continued. For convenience the figure is repeated.)

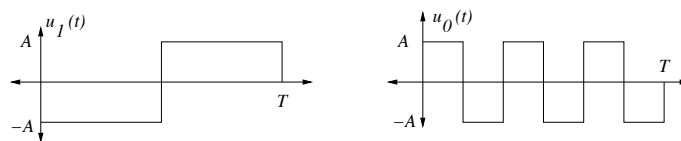

(d) Consider the suboptimal receiver in which the received waveform is correlated with the signal  $s_1(t)$  and the correlator output is compared with a threshold. What is the minmax optimal choice of threshold in the suboptimal receiver? What is the resulting value of the probability of error? What is the total effective loss in energy efficiency, expressed in dB, for not using an ideal coherent detector and for not using an antipodal pair of signals?

(e) Consider the noncoherent receiver shown below.

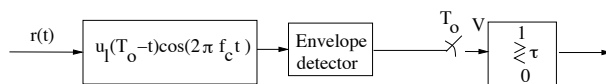

Given that  $m = 1$  is sent, describe the distribution of  $V$ . Identify parameter values in terms of  $A, T$ , and  $N_o$ .

3. (28 points) Consider a QPSK system with transmitted signal

$$s(t) = \sum_n [Aa_{n,c}g_T(t-n)\cos(2\pi f_c t + \phi) - Aa_{n,s}g_T(t-n)\sin(2\pi f_c t + \phi)]$$

such that  $g_T(t) = \sin(\pi t)I_{[0,1]}(t)$ , the data symbols  $a_{n,c}$  and  $a_{n,s}$  are all in  $\{1, -1\}$ , and  $f_c \gg 1$ . Note that the symbol duration is one.

(a) Sketch the signal  $s$  over the time interval  $[0, 3]$ , assuming whatever symbol values you'd like. Then identify the lowpass equivalent signal  $s_l$ . (Hint: It is the complex-valued baseband signal such that  $s(t) = \text{Re}(s_l(t)e^{j2\pi f_c t})$ . Note that this part of the problem is independent of the rest.)

Suppose the signal  $s$  is corrupted by AWGN with two-sided power spectral density  $\frac{N_0}{2}$  to produce the received signal  $r$ , which is fed into the receiver indicated.

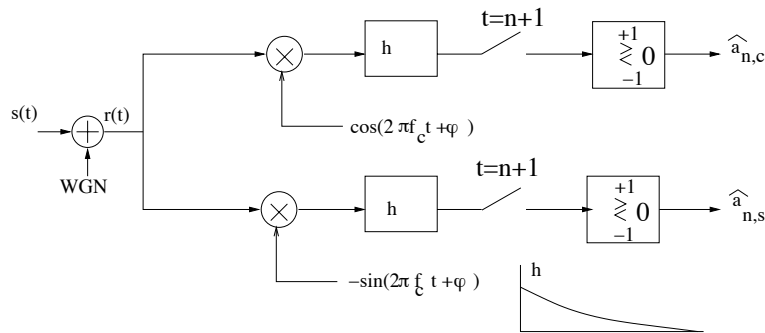

The receive filter  $h$  is given by  $h(t) = e^{-t}$  for  $t \geq 0$  and  $h(t) = 0$  for  $t < 0$ , and perfect phase tracking is assumed.

(b) Ignoring the effects of intersymbol interference, find the average probability of error. Roughly how many dB loss is there compared to that of the ideal matched filter receiver? Hint:  $\int_0^1 e^{-t} \sin(\pi t) dt \approx 0.40$ .

$p_e =$

dB loss over optimal receiver =

Problem 3 continued. For the remainder of this problem, the effects of intersymbol interference are to be taken into account. The block diagram is repeated for convenience.

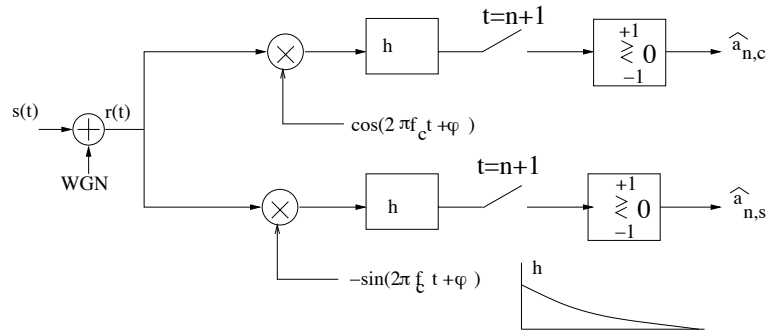

(c) Do the bits in the quadrature signal interfere with the bits in the inphase signal? Explain.

(d) Identify the worst case bit sequence for receiving bit  $a_{0,c}$ , and find the corresponding maximum error probability. (Hint:  $e^{-1} \approx 0.38$ .)

Worst case bit pattern =

$p_{\max} =$

*Problem 3 continued.*

(e) Suppose a three-tap equalizer is inserted after the filter in each branch of the receiver, and that the vector of tap weights  $(c_{-1}, c_0, c_1)$  is chosen to minimize the peak relative distortion. Find the tap weights.

$$(c_{-1}, c_0, c_1) =$$

(f) Repeat part (d), but now with the equalizer installed. (Hint: Account for the effect of the equalizer on the noise.)

Worst case bit pattern =

$$p_{\max} =$$

(g) Of the answers to parts (b), (d), and (f), which is the largest error probability? Which is smallest?

Largest error probability:

Smallest error probability:

4. (24 points) This problem focuses on using trellis coded modulation using the following 8-ary QAM constellation, where the coordinates are taken relative to an orthonormal basis for the signal space.

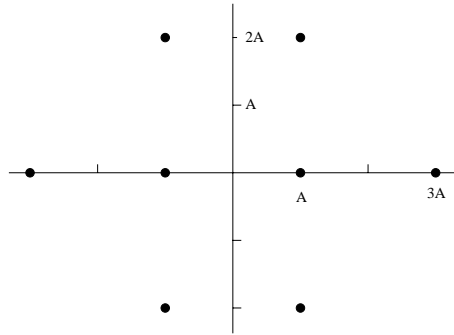

Suppose the  $(n = 2, k = 1)$  convolutional code with generators  $\mathbf{g}_1 = [1 \ 0 \ 1]$  and  $\mathbf{g}_2 = [1 \ 1 \ 1]$  is used to produce two coded bits per data bit to select one of 4 subconstellations, and then an additional uncoded data bit is used to specify a symbol within the selected subconstellation. This scheme has the same bandwidth requirement as an uncoded QPSK system.

(a) Express the energy per data bit,  $\mathcal{E}_b$ , in terms of  $A$ . (Remember that there are two data bits per symbol.)

(b) Apply the method of set partitioning to the signal constellation. As in the text, label the original constellation  $A$ , the two subconstellations below it  $B_0$  and  $B_1$ , and the four constellations below those,  $C_0, C_2, C_1$ , and  $C_3$ .

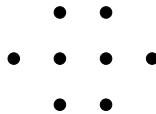

*Problem 4 continued*

(c) Show a labeling of the signal constellation, following the design guidelines given in the text.

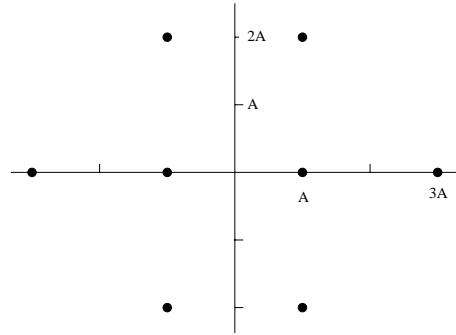

(d) Sketch three stages of the trellis, and indicate the corresponding transmitted symbols on the edges. Your answer should lead to the largest possible Euclidean distance for deviating paths of length one and length three. (Two templates are given for convenience. If one is used only for scratch, cross it out.)

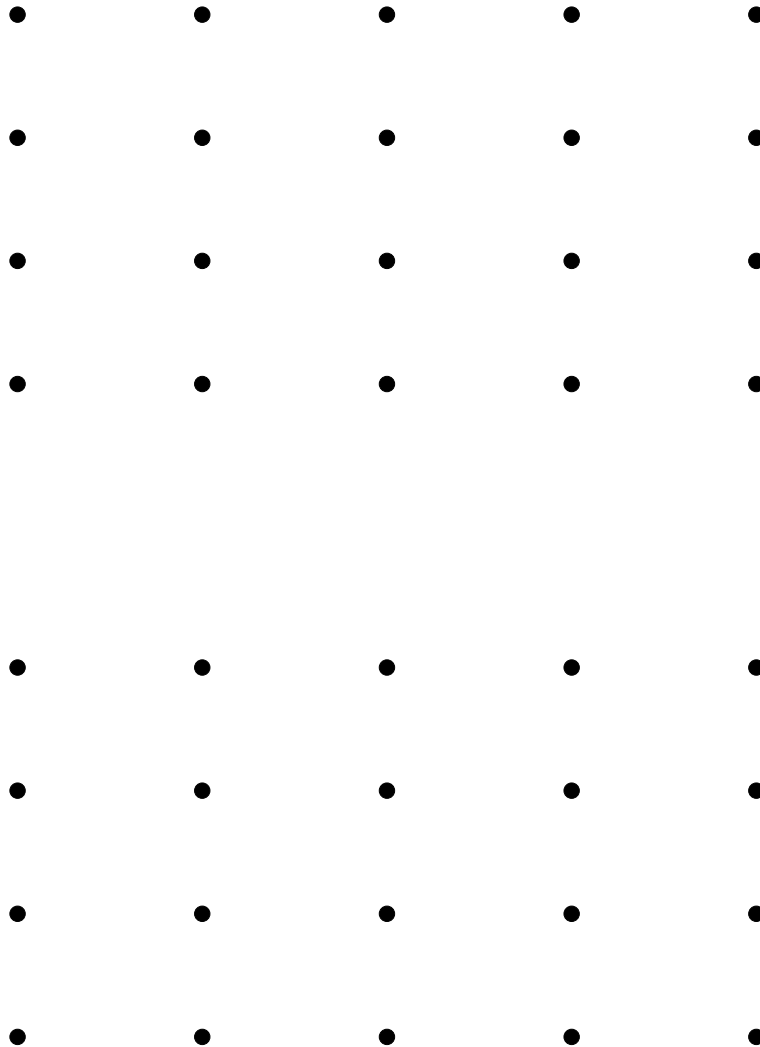

(e) What is the minimum free Euclidean distance squared for a deviating path of length one edge? Of length three edges? Of length four edges? (Express your three answers in terms of  $A^2$ )

(f) Using the answers to parts (a) and (e), give a three term approximation to the bit error probability (e.g. the first three terms of the union bound) in terms of the  $Q$  function and  $\frac{E_b}{N_o}$ . What is the approximate energy efficiency gain over uncoded QPSK (which has the same spectral efficiency)?